

FLG SERIES

Sight Level Gauges



FILTRATION PRODUCTS CORP.

(763) 428-6415

Fax: (763) 428-8659
18151 Territorial Road
Dayton, MN 55369
www.filtrationproducts.com

FP-22559-99

FEATURES

O-Ring type construction

3 Sizes: 3", 5" and 10" between bolt centers

For non-pressurized tanks only

Can be mounted on tapped holes

Suitable for mineral / petroleum based fluids

Thermometer standard

FLG SERIES

Sight Level Gauges



FLG10T



FLG5T



FLG3T

DIMENSIONS

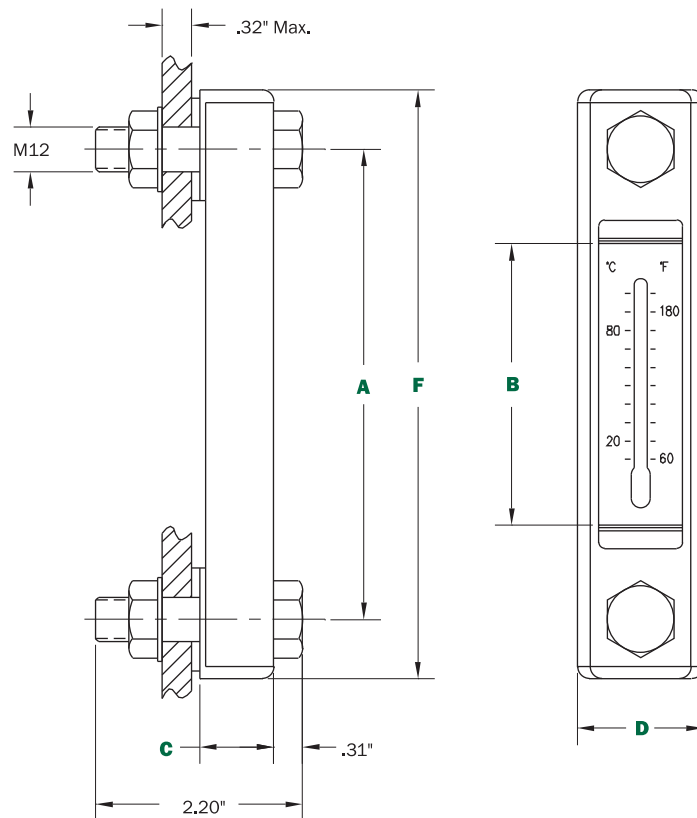

SPECIFICATIONS

MODEL NUMBER	DIMENSIONS					WEIGHT (lbs)
	A	B	C	D	F	
FLG3T	3"	1.5"	.8"	1.3"	4.25"	.44
FLG5T	5"	3"	.8"	1.3"	6.26"	.53
FLG10T	10"	8"	.8"	1.3"	11.26"	.62