

# 50 SERIES

## Spin-On Filter Head



### SPECIFICATIONS

<b>Working Pressure</b>	100 PSI (6.85 BAR) Maximum 75 PSI Maximum without bypass
<b>Flow Capacity</b>	50 GPM (378 LPM)
<b>Operating Temperature</b>	225°F (107°C) Maximum
<b>Shipping Weight</b>	12 lbs
<b>Fluid Compatability</b>	Petroleum based oils, high water based fluids, water glycols and oil/water emulsions.
<b>By-Pass Valve Cracking Pressure</b>	All sizes +/-10% of setting
<b>Post Size</b>	1-1/2" - 16 UN and 1-1/4" BSP

# STANDARD MODELS

MODEL NUMBER	PORT SIZE	BY-PASS	INDICATOR PORTS
50044A	1-1/4" NPT	25 PSI	(2) 1/8" NPT
50044X	1-1/4" NPT	25 PSI	(2) 1/8" NPT
50184A	1-1/4" NPT	25 PSI	(2) 1/8" NPT
50184X	1-1/4" NPT	25 PSI	(2) 1/8" NPT

# ORDERING CODE

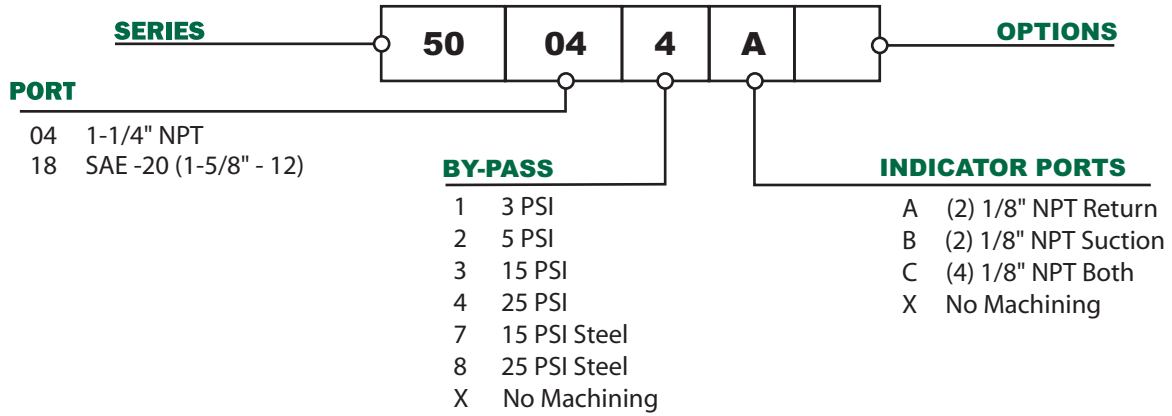

# DIMENSIONS

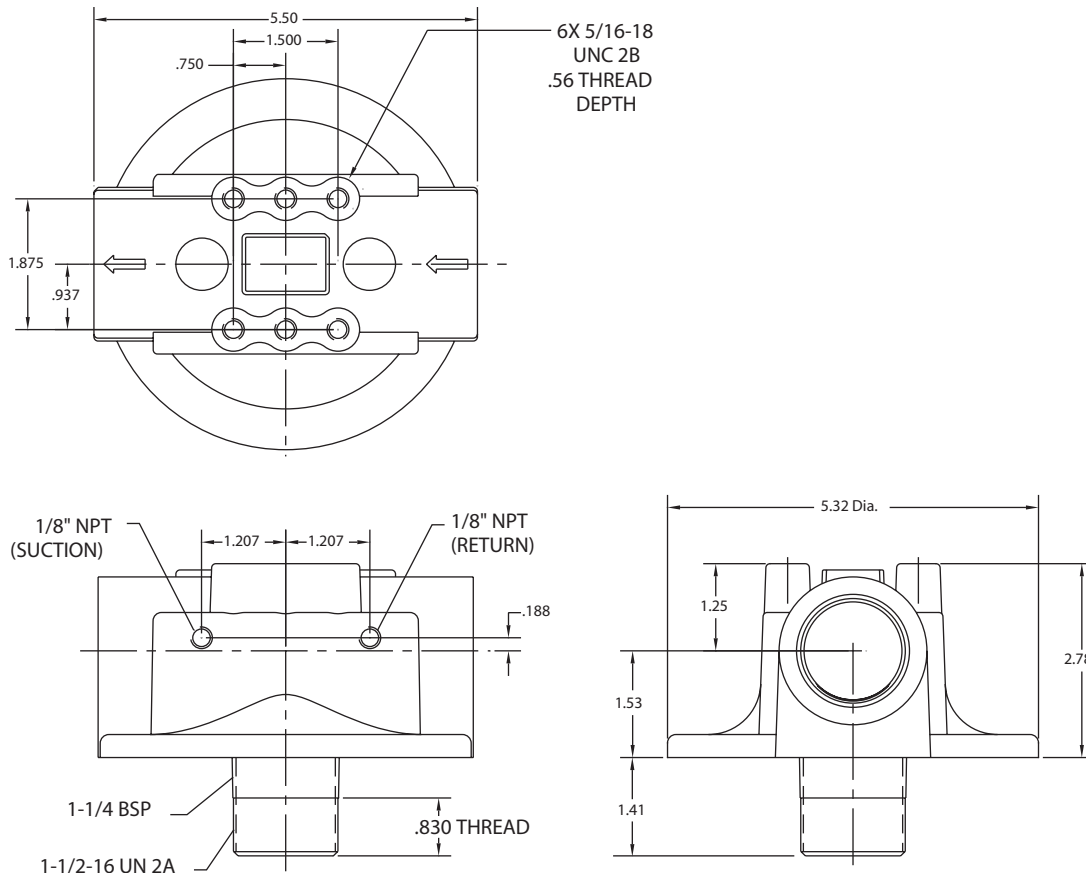

# 50 SERIES

## Spin-On Filter Head



### ACCESSORIES

#### GAUGES

- P77-7003**  
0-60 PSI Gauge (Indication at 15 PSI)
- P77-7004**  
0-60 PSI Gauge (Indication at 25 PSI)
- P77-7021**  
0-30" Hg Vacuum Gauge

#### SWITCHES

- P77-7006**  
Electrical (with 12" wire leads)  
Set point (rising) 22 PSI.
- P77-7005**  
Electrical (with DIN 43650 connector)  
Set point (rising) 22 PSI.

### PRESSURE DROP

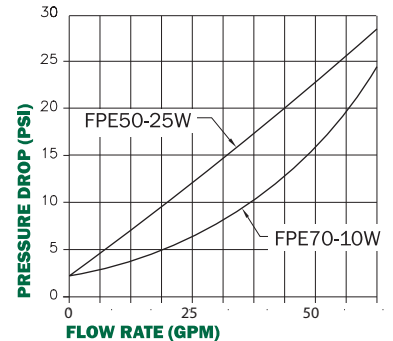
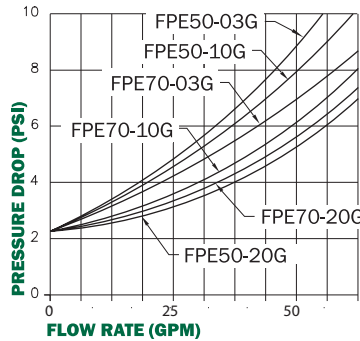
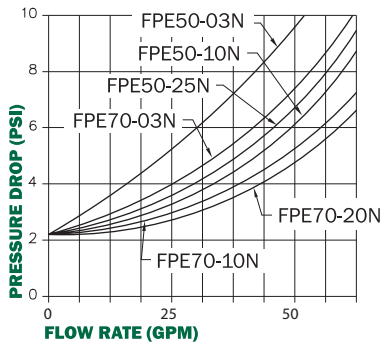

### FILTER ELEMENTS

PART NUMBER	ELEMENT LENGTH	RATING B(x)=2/20/75	AREA (Sq. In.)	MEDIA TYPE
FPE 50-03N	7"	1μ/8μ/12μ	850	Cellulose
FPE 70-03N	11"	1μ/8μ/12μ	1530	Cellulose
FPE 50-10N	7"	14μ/28μ/36μ	664	Cellulose
FPE 70-10N	11"	14μ/28μ/36μ	1227	Cellulose
FPE 50-25N	7"	16μ/35μ/47μ	568	Cellulose
FPE 70-25N	11"	16μ/35μ/47μ	1052	Cellulose
FPE 70-10W	11"	10μ/18μ/ -	648	Water Removal
FPE 50-25W	7"	10μ/20μ/ -	360	Water Removal
FPE 50-03G	7"	1.5μ/2.5μ/3μ	490	Microglass
FPE 70-03G	11"	1.5μ/2.5μ/3μ	882	Microglass
FPE 50-10G	7"	2μ/7μ/12μ	490	Microglass
FPE 70-10G	11"	2μ/7μ/12μ	882	Microglass
FPE 50-20G	7"	7μ/16μ/23μ	490	Microglass
FPE 70-20G	11"	7μ/16μ/23μ	882	Microglass
FPE 50-100M	7"	149μ	213	Wire Mesh
FPE 70-100M	11"	149μ	365	Wire Mesh



## **FILTRATION PRODUCTS CORP.**

**763.428.6415**

Fax: 763.428.8659

18151 Territorial Road, Dayton, MN 55369

[www.filtrationproducts.com](http://www.filtrationproducts.com)